



# Vestil Manufacturing Corp.

2999 North Wayne Street, P.O. Box 507, Angola, IN 46703

Telephone: (260) 665-7586 -or- Toll Free (800) 348-0868

Fax: (260) 665-1339

www.vestilmfg.com e-mail: [info@vestil.com](mailto:info@vestil.com)

## SWA-48 and SWA-48-PMO Instruction Manual

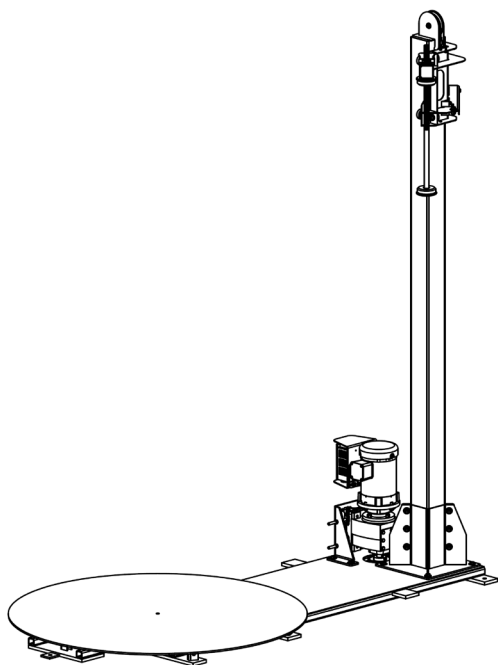

SWA-48

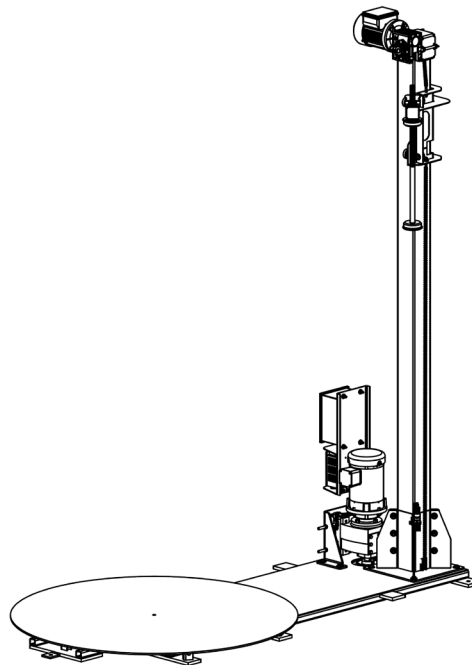

SWA-48-PMO

### Receiving instructions:

After delivery, remove the packaging from the product. Inspect the product closely to determine whether it sustained damage during transport. If damage is discovered, immediately record a complete description of the damage on the bill of lading. If the product is undamaged, discard the packaging.

### Note:

The end-user is solely responsible for confirming that product design complies with all laws, regulations, codes, and mandatory standards applied where the product is used.

### Table of Contents

Signal Words.....	2
Hazards.....	2
Introduction.....	3
Installation.....	3
Stretch Wrap Holder Assembly.....	4
Adjusting Belt Tension.....	5
Operation.....	5, 6, 7
Exploded Views & Bills of Materials.....	8, 9, 10, 11
Operating the Powered Mast.....	12
Labeling Diagram.....	12
Record of Satisfactory Condition.....	13
Inspections & Maintenance.....	13
Troubleshooting.....	14
Electrical Circuit Diagrams.....	15, 16
Limited Warranty.....	17

## Signal Words

This manual uses SIGNAL WORDS to draw the reader's attention to safety-related information. Signal words indicate the likelihood of personal injuries as well as the probable seriousness of those injuries, if the product is misused in the ways described. Other signal words call attention to uses of the product likely cause property damage. Signal words used in this manual appear below along with the meaning of each word:



Identifies a hazardous situation which, if not avoided, WILL result in DEATH or SERIOUS INJURY. Use of this signal word is limited to the most extreme situations.



Identifies a hazardous situation which, if not avoided, COULD result in DEATH or SERIOUS INJURY.



Indicates a hazardous situation which, if not avoided, COULD result in MINOR or MODERATE injury.



Identifies practices likely to result in product/property damage, such as operation that might damage the product.

## Hazards

Vestil diligently strives to identify foreseeable hazards associated with the use of its products. However, material handling is inherently dangerous and no manual can address every conceivable risk. The end-user ultimately is responsible for exercising sound judgment at all times.



If this product is used improperly or carelessly, personal injuries might result.

- DO NOT modify the product in any way UNLESS you first obtain written approval from Vestil. Unauthorized modifications automatically void the *Limited Warranty* and might make the product unsafe to use.
- Read the manual whenever necessary to refresh your understanding of proper use and maintenance procedures.
- DO NOT exceed the capacity of the unit. See Label 287 in *Labeling diagram* on p. 12.
- DO NOT stand, or sit, on the turntable or the load at any time.
- Install the machine ONLY on even, level surfaces where it will not be exposed to the outdoor environment.
- Keep hands, clothing, etc. out of contact with all moving parts of the machine during operation.
- During operation, stand with the mast between yourself and the turntable.
- DO NOT activate the turntable UNLESS the load is centered on it and stable. Rotation can cause the load to become unstable, so be prepared to stop the turntable. An unstable load might topple during the wrapping process. EVERY person in the area should remain far enough away from the machine to avoid contact with the load if it falls. Higher rotation speed, in particular, might cause an unstable load to slide off of the turntable.
- DO NOT continue to use the machine if you observe abnormal motion or noise. Immediately tag the unit "Out of service" and report the problem to maintenance personnel.
- If you notice a malfunction during operation, DO NOT attempt to resolve it unless you are both authorized to do so and *certain* that it will be safe to use afterwards. The unit must be in satisfactory condition whenever it is used. See *Record of Satisfactory Condition* and *Inspections & Maintenance* on p. 13.
- Inspect the product as directed on page 13. DO NOT use the machine unless it is in satisfactory condition.
- DO NOT use this machine UNLESS all labels are in place, readable, and undamaged. See *Labeling Diagrams* on p. 12.



Proper use, maintenance, and storage are essential for this product to function properly.

- Always use this product in accordance with the instructions in this manual and consistent with any training relevant to machines, devices, etc. used in conjunction with this product.
- Periodically lubricate the chain.
- Keep the product clean & dry.
- Vestil uses only quality parts to make the equipment we manufacture. Vestil bears no responsibility for problems that result as a consequence of using unapproved replacement parts. To order replacement or spare parts for this equipment, contact the factory.

## Introduction

Vestil's Medium Duty Powered Stretch Wrap Machines offer the same great features as our standard duty machines in a 5,000-lb capacity unit. Complete with a powered turntable and counter-balanced stretch film mast. To operate, depress the foot pedal and manually move the mast up and down. The film-wrap tension is controlled with an adjustable, friction-brake assembly. Film placement is controlled manually by moving the carriage assembly up and down on the vertical mast. A hand operated carriage-brake allows the carriage to move freely making film application fast and simple. The system will accept 10" to 20" material. The unit ships with the mast disconnected, simply raise the mast and clamp into place. The standard manual film wrap delivery can be upgraded to 120 volt; 1-phase AC powered mast option, PMO. The hand held control is used to raise/lower the film while the foot control is used to operate the turntable. Please contact factory for Approach Ramp options on these models.

## Installation

Review this entire instruction set before installing the stretch-wrap machine. Consult the manufacturer in the event there are any questions or problems at the time of installation, or for information regarding optional features not covered by the owner's manual. The model SWA-48 stretch-wrap machine must be removed from the shipping wood and securely anchored to the floor before use!

- Modifications or the addition of ancillary equipment to any part of the stretch-wrap machine without prior manufacturer's authorization may void the machine's warranty.
- The installation should be made so that it complies with all regulations applicable to the machine and its location. The end-user must verify that the supplied equipment is installed so it will be suited to the environment in which it will be used.
- Installation must be performed by suitably trained personnel with access to the appropriate equipment. The electrical aspects of the installation should be performed by an electrician.
- Choose a location for the machine that will be free of obstructions to the largest diameter load that could be placed on the turntable. Consideration should also be given to the approach path(s) of pallet trucks and fork trucks so that personnel, the motor speed control, and the foot switch and its cord can be adequately protected from injury or damage.

For a typical installation, you will need the following:

1. A fork truck or hoisting means to unload the machine from the freight truck and to set it into place.
2. A smooth, level, and adequately strong concrete surface on which to mount the machine's frame.
3. Concrete anchors, a masonry drill, a masonry bit, hand tools, grout, and steel shims. Consult the building's architect or facility engineer to determine the best size and type of hardware with which to anchor the machine to the floor.
4. A power supply circuit and disconnect matching the motor voltage and current requirements. Refer to the machine's data plate, to the labels on the control enclosure, and to the electrical section in this manual, for more information. The end-user is responsible for supplying the branch circuit's required (by code) overcurrent and short circuit protection.

Note: Static electricity is produced on the stretch-wrap film as it pulls off the roll during the stretch-wrapping of a palletized load. The static effect might intensify in dry air. If undesirable effects of static on personnel or product are experienced, consult an ESD (electrostatic discharge) product supplier for available methods to dissipate static.

- Machine Installation: Numbers in parentheses () correspond to item numbers in the Exploded View on p. 8.**
1. Move the machine to its installation location with a fork truck. Insert the forks lengthwise along each side of the frame. Adjust fork spacing (on the forklift carriage) so that the forks lie underneath the 1/2" x 3" x 3" anchoring tabs on each side of the frame. Be careful to avoid damaging the electrical components.
  2. Prop up the motor end of the frame (1), for instance with 4" x 4" lumber or something similar.
  3. Stand the mast (18) upright on the end of the frame opposite the turntable. Standing at the end of the frame opposite the turntable, the mast must be oriented with the (stretch wrap) carriage on the left side of the frame. Align the hole in each corner of the mast mounting plate with its corresponding hole in the frame.
  4. Bolt the mast to the frame with the hardware provided, and wrench-tighten.
  5. Remove the counterbalance retaining screw. The screw is located approximately 12" up from the bottom of the mast. Cut the cable tie holding the mast cable to the pulley at the top of the mast.
  6. Anchor the frame to the floor. There are 9/16" holes located at the corners of the frame and under the edge of the turntable. Tighten the anchors until the frame is level.
  7. Shim and/or apply grout under the frame wherever the frame is not in contact with the ground to prevent bowing.
  8. Tighten all of the anchor bolts with an appropriately sized wrench.
  9. Bolt the motor & drive assembly (15) onto the gear reducer using the included hardware and shaft key. When finished, the drive controller should face the right side of the frame.
  10. Connect the (turntable) power cord plug to a standard 15A or 20A, 120 VAC receptacles. If a powered mast (see p. 18) is installed, the turntable power cord can plug into the pigtail cord from the mast's control enclosure. Plug the mast's power cord into a 120V receptacle to supply both the mast and turntable with electricity.
  11. Verify that the turntable rotates and that the speed control knob provides full speed range adjustment. If a powered mast is installed, verify that the mast operates (see [Operating the Powered Mast](#) on p. 12) and that the mast's upper and lower travel limit switches function properly.
  12. Clean up debris. Confirm that all labels are intact and easily readable. See [Labeling diagram](#) on p. 12.

### Stretch Wrap Holder Assembly

The wrap holder accommodates 10-20 inch rolls of stretch wrap.

#### Loading stretch wrap:

1. Unwind the wing nut (A) sufficiently to remove the lock spacer (6) underneath the bottom retainer (2).
2. Remove the lock spacer.
3. Remove the retainer (5) and bearing (4).
4. Remove the spent roll of stretch wrap and install a new roll.
5. Reinstall the retainer (5); secure it in place with the lock spacer (6).
6. Tighten the wing nut (A) until the roll is snugly grasped between the tube retainers (2) and (3). Adjust the tightness of the wing nut to achieve the desired degree of material stretch—the material will stretch more the more tightly the roll is grasped.

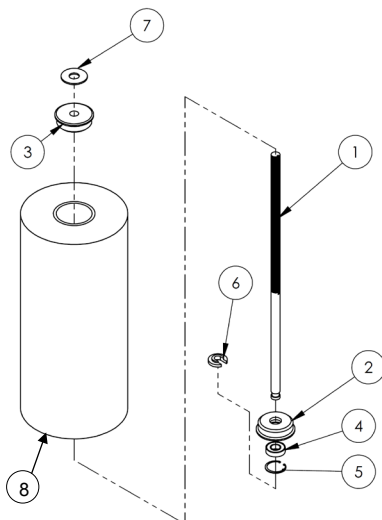
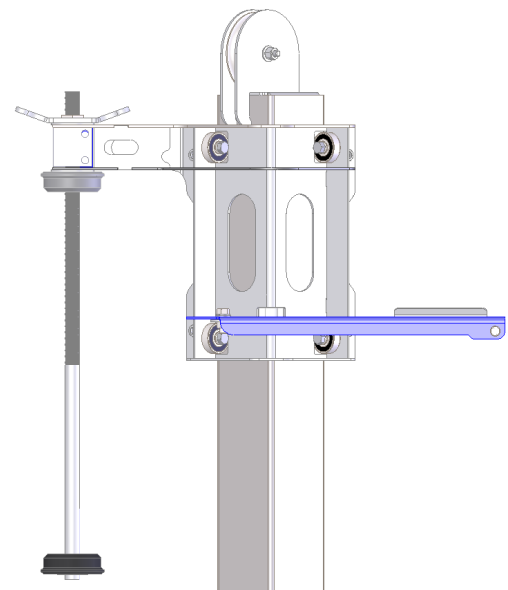

Item	Part no.	Description	Qty.
1	20-014-116	Frame, rod, wrap retainer	1
2	20-014-006	Tube retainer (bottom)	1
3	20-014-005	Tube retainer (top)	1
4	20-110-002	Bearing, ball, 3/4 in., shield	1
5	68061	1 5/8 in. retainer ring	1
6	20-113-022	Spacer, lock	1
7	20-113-003	7/8 in. fiber washer	1
*8	SRF-18	20in. plastic wrap (not included)	1

**Adjusting Belt Tension:**

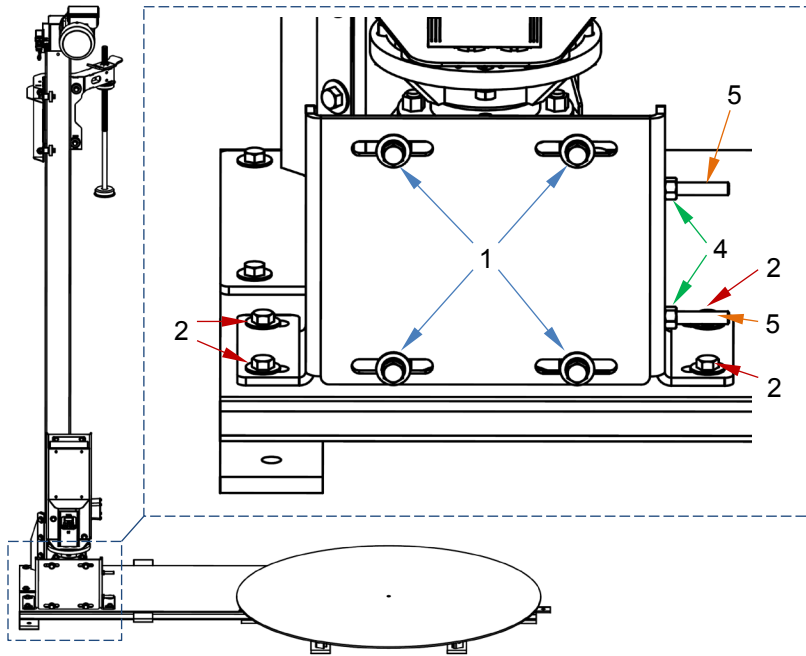

- Numbers in the diagram to the left correspond to the procedure numbers below.
1. Loosen all 4 bolts which hold the gear reducer to its mounting bracket.
  2. Loosen the mounting bolts and slide the bracket to the left.
  3. Retighten the bolts loosened in step 1.
  4. Loosen the jam nuts.
  5. Turn the screws clockwise to increase belt tension (CCW to reduce tension).
  6. Retighten the jam nuts (4) and mounting bolts (2).

Operation

**Ensure that all employees involved in the operation and care of this machine fully understand and consistently apply these instructions.**

The standard model SWA-48 is suitable for moderate-duty, intermittent cycling with a 4,000 pound load. It is intended to be used indoors in industrial and commercial locations to apply stretch-wrap material at between three and twelve revolutions per minute (RPM) in a clockwise rotation around palletized, stable, non-hazardous loads. The maximum diameter (or diagonal, measured corner-to-corner) load size for the SWA-48 is 76”, the maximum load height is 78”. Always ensure that the load is centered on the turntable.

The material mast can utilize stretch-wrap material rolls in lengths from 10” to 20” — spacer tubes stored on the material rod allow for the use of several material roll lengths below 20”. The SWA will generally be capable of achieving stretch-wrap material stretch rates of 150-200%.



**Loading:**

<b>⚠ WARNING</b>	<ul style="list-style-type: none"> <li>• Verify that no part of the load is overhanging below the turntable. A damaged skid with a dragging board or an overhanging load that sags below the turntable can cause the entire load to shift suddenly if it catches on the frame.</li> </ul>
<b>⚠ CAUTION</b>	<ul style="list-style-type: none"> <li>• Do not exceed the machine’s load ratings. Damage or premature failure to the drive system or its components could result from exceeding the listed capacity. Place loads onto the turntable slowly and gently using a pallet truck or walk-behind fork lift, using an optional approach ramp, or with a fork truck.</li> <li>• Do not drop loads onto the turntable. Even a two-inch drop onto the turntable creates a shock load on the load bearings that will result in their premature failure.</li> <li>• See the installation page in this manual for instructions on how to install a roll of stretch-wrap material onto the mast carriage.</li> </ul>

The load rating, in pounds, is shown on the machine data plate located on the frame near the gear reducer mounting bracket. It indicates the net capacity of the turntable with a load that is centered and evenly distributed.

Note: The addition of any ancillary equipment to the turntable, such as a conveyor, must be taken into account when determining the net load applied to the turntable.

**Operation:**

	<ul style="list-style-type: none"> <li>• Keep all personnel clear of the machine when it is in operation. Be certain no part of any person, fork truck, or other object is in the path of the rotating load before rotating the turntable.</li> <li>• Do not stand or sit on the turntable or its load at any time.</li> <li>• Keep all body parts and clothing away from the machine's drive system(s).</li> </ul>
	<p>Do not use the stretch-wrap machine if any damage or unusual noise is observed, if it is in need of repairs, or if it seems to be malfunctioning. Notify your supervisor or maintenance personnel if you notice anything out of the ordinary.</p>

The standard stretch-wrap machine is furnished with a constant-pressure (dead-man style) foot switch control. Pressing the foot switch will turn on the motor to rotate the turntable. The turntable will rotate only while the control is pressed. Upon releasing the control, the turntable will coast to a stop.

The turntable speed can be adjusted with the speed control knob on the front of the motor speed control. The display on the front of the motor controller shows the approximate RPM of the turntable. Turn the speed control knob clockwise to increase the turntable speed, and counterclockwise to decrease the speed.

Pull the handle upward to move the stretch-wrap material roll upward. Push the handle down to move the material downward. Control of the tension/stretch of the stretch-wrap material is achieved by turning the handle on top of the material.

Screw the handle clockwise, downward, to increase the material tension and stretch, and turn it counterclockwise, upward, to decrease the material stretch.

	<p>Always carefully watch the palletized load while the turntable is rotating.</p>
--	--

Set the material tensioner so the material will pull off the roll easily. Pull stretch-wrap material off the roll and either hold or tie it to the load to be wrapped. Press the foot switch to rotate the load.

After one or two overlaps, tension the material to the desired stretch rate. Raise and lower the material carriage until the load is covered 100%, with two or three overlaps. While the turntable is still rotating, the material can either be cut with a knife or torn with the hands. Press and smooth the cut end of the material up against the side of the load.

**Note:** Best results for palletized loads are generally achieved by having the wrap overlap the sides of the pallet at the bottom and extending slightly above the load at the top. Ensure that all safety and warning labels stay in place and are legible. Refer to the [Labeling Diagram](#) on p. 12.





**Changing Delta Motor Speed Controller Parameters:**

Press  to switch to the program mode.

a) The following screen, , will appear.

This indicates the specific parameter group.

b) Use the buttons, shown on the next page, to change all parameter settings.

	Press "PROG/DATA" button to select parameter group and to store entered data. "END" displays for approx. 0.5 sec. if input has been accepted.
	Press "MODE" to scroll through all status at the drive; To show the turntable speed on the display, press "mode" three times after initial power-up. For example, when the turntable is rotating at 12 rpm, the display will appear as "u 12."
	Press "UP" or "DOWN" button to scroll through different parameters.
	Press "UP" or "DOWN" button momentarily will change parameter settings in single-unit increments.

### Drive Parameter Settings

Parameter	Parameter Description	Setting	Setting Description
0-03	Start-Up Display Selection	d 2	Display the content of user-defined unit.
0-05	User Defined Coefficient K	d 0.3	Scales the frequency value so the display shows the approximate turntable rpm.
1-02	Maximum Output Voltage	d 255	Sets the maximum voltage to the motor
1-07	Upper Bound of Frequency	d 65	Sets the maximum rotation speed with the speed knob turned fully clockwise (about 11 rpm).
1-08	Lower Bound of Frequency	d 15	Sets the minimum rotation speed with the speed knob turned fully counterclockwise (about 3 rpm).
1-09	Acceleration Time 1	d 10	Time to accelerate the motor to the drive's maximum output frequency set point, in seconds.
1-15	Auto Acceleration / Deceleration	d 0	Allows for a linear acceleration rate of the motor.
1-16	S-Curve in Acceleration	d 7	Determines how smoothly the drive accelerates.
2-00	Source of Frequency Command	d 3	Allows the turntable speed to be controlled by the knob of the drive's keypad.
2-01	Source of Operation Command	d 1	Makes the drive turn on the external foot switch.
2-02	Stop Method	d 1	Allows the turntable to coast to a stop.
6-02	Over-Current Stall Prevention Level	d 150	Sets the maximum motor current, as a percentage of the drive's rated output.
6-03	Over-Torque Detection Mode	d 3	Detection is enabled during Acceleration and continues until the Continuous Output Time Limit is reached.
6-04	Over-Torque Detection Level	d 200	Sets the maximum output torque, as a percentage of the drive's rated output.
6-05	Continuous Output Time Limit	d 10	Determines the time the drive will run after over torque is detected, in seconds.
7-00	Motor Rated Current	d 120	Affects the point at which the drive limits its output current, in percent of drive's rated output.
7-01	Motor No-load Current	d 75	Affects the drive's motor slip compensation.
7-02	Torque Compensation	d 10	Controls the motor's maximum start-up torque.

### SWA-48 Exploded View and Bill of Materials

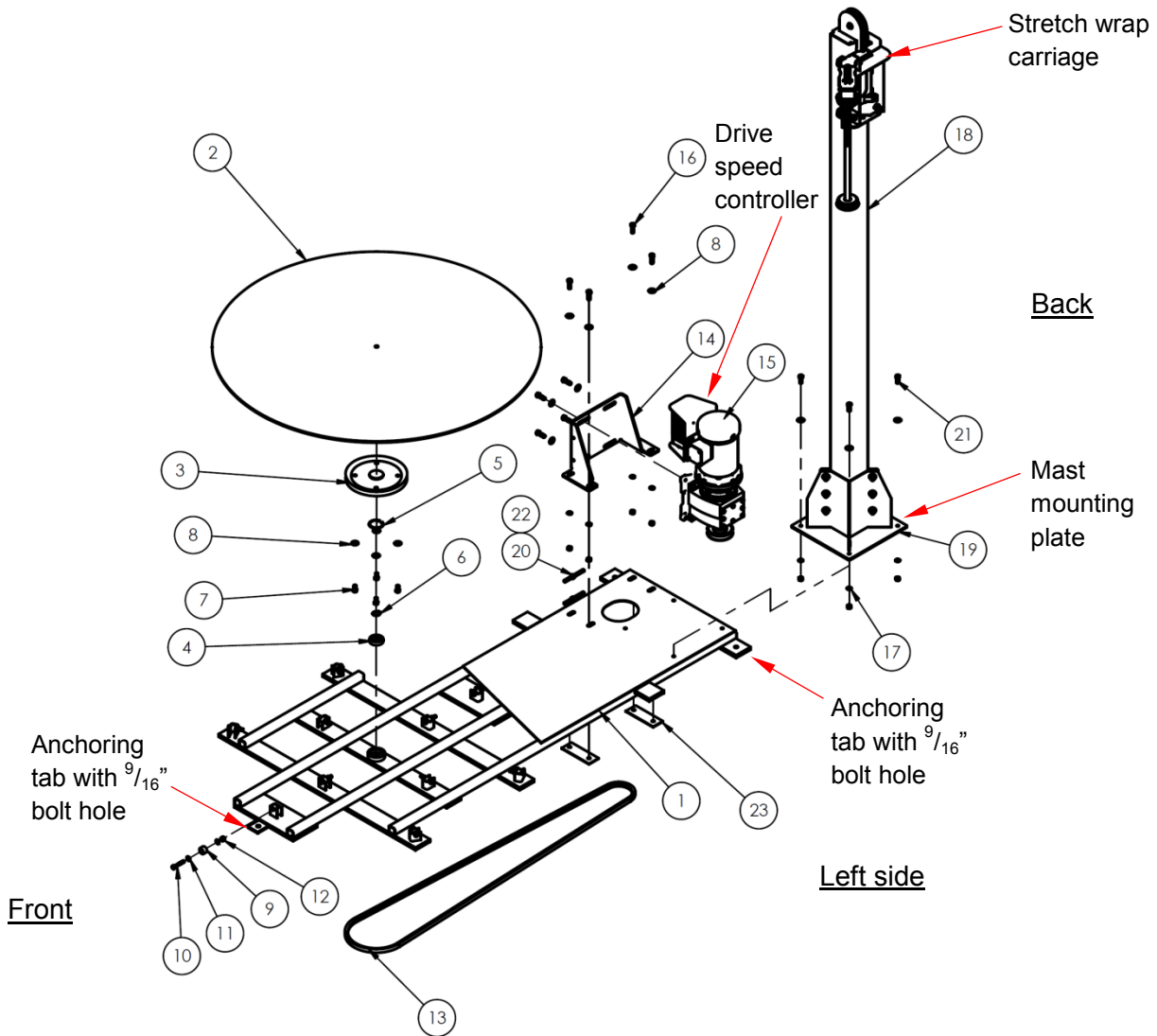

Item	Part no.	Description	Qty.	Item	Part no.	Description	Qty.
1	20-514-006	Weldment, main frame	1	13	20-042-020	Belt, B115	1
2	20-513-001	Weldment, turntable deck	1	14	20-016-032	Bracket, motor mount, formed	1
3	20-542-006	Weldment, pulley/pin	1	15	20-641-006	Subassembly, control box/motor/reducer, 115VAC	1
4	20-110-001	Single row ball bearing, shielded	1	16	13107	Bolt, 3/8"-16x1 1/4", HHCS, #5, zinc plated	8
5	20-117-001	Internal retaining ring, 2"	1	17	33622	Split lock washer, carbon steel, medium zinc finish, 3/8"	12
6	20-117-003	External retaining ring, 1" dia.	1	18	20-514-084	Subassembly, counter-balanced mast, manual	1
7	11103	Hex bolt, grade A, zinc plated, 3/8"-16x3/4"	4	19	20-001-153	Bracket, mast mount	1
8	33008	Flat washer, low carbon, USS, zinc plated, 3/8"	16	20	36106	Hex nut, grade a, zinc plated, 3/8"-16	10
9	20-110-003	Cam roller with seal	10	21	11105	Hex bolt, grade A, zinc plated, 3/8"-16x1"	4
10	11061	Bolt, HHCS #2, zinc plated, 5/16"-18x2"	10	22	25552	Socket set screw, black oxide, 3/8"-16x4"	2
11	33004	Flat washer, USS, zinc plated, 1/4"	20	23	20-016-033	Bracket, motor mount	2
12	37021	Nylon insert lock nut, grade 2, zinc finish, 5/16"-18	10				



Manual, counterbalanced mast subassembly exploded view & bill of materials (20-514-084)

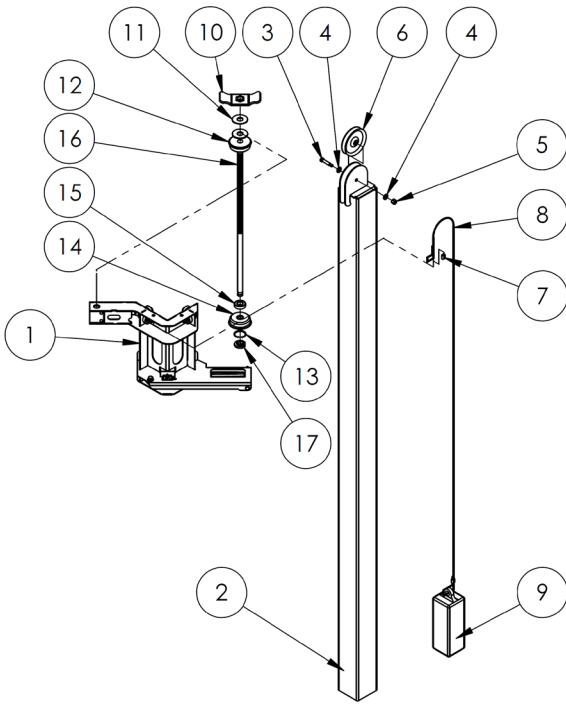

Item	Part no.	Description	Quantity
1	20-538-005	Subassembly, carriage	1
2	20-514-082	Subassembly, mast, manual	1
3	26333	Shoulder screw 0.375in. x 1.5in.	1
4	33008	<sup>3</sup> / <sub>8</sub> in. USS zinc-plated flat washer	2
5	37024	<sup>3</sup> / <sub>8</sub> in. Nylock insert nut	1
6	20-027-001	Pulley, counterweight	1
7	20-145-019	Specialty hardware, swage sleeve	2
8	20-145-018	Specialty hardware, cable	1
9	28-014-179	Cast, counterweight (SWA-48)	1
10	20-620-001	Weldment, specialty hardware, rod tension wing nut	1
11	20-113-003	<sup>7</sup> / <sub>8</sub> in. fiber washer	2
12	20-014-005	Frame, tube retainer, (top)	1
13	68061	<sup>1</sup> / <sub>8</sub> in. retainer ring	1
14	20-014-006	Tube, retainer, (bottom)	1
15	20-111-002	Bearing, 7R16	1
16	20-014-116	Frame, rod, wrap retainer	1
17	20-113-022	Spacer, lock	1

Stretch wrap carriage subassembly exploded view & bill of materials (20-538-005)

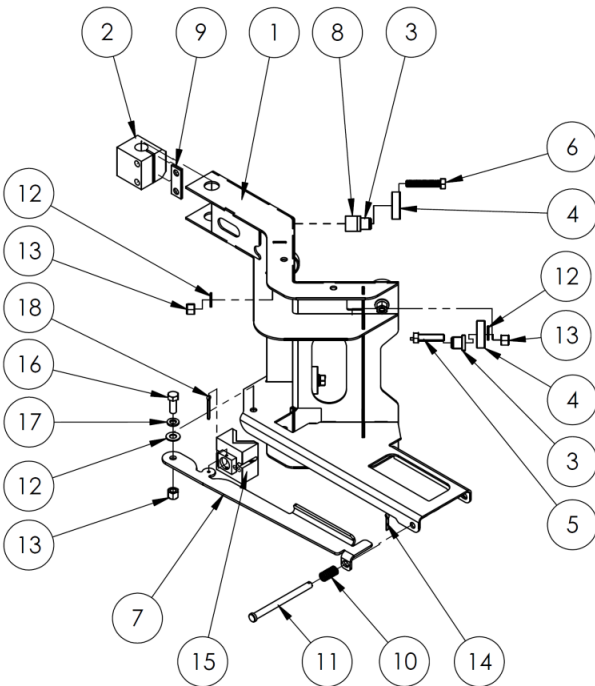

Item	Part no.	Description	Quantity
1	20-514-080	Weldment, carriage frame	1
2	20-145-010	Specialty hardware, clamp, wrap, mounting	1
3	21-113-021	Spacer, bearing shaft	8
4	20-110-006	Roller bearing	8
5	11109	<sup>3</sup> / <sub>8</sub> in. – 16 x 1 <sup>1</sup> / <sub>2</sub> in. HHCS #2 zinc-plated bolt	4
6	11111	<sup>3</sup> / <sub>8</sub> in. – 16 x 2in. HHCS #2 zinc-plated bolt	4
7	20-040-001	Lever, brake release, formed	1
8	21-113-020	Spacer, bearing	4
9	20-113-023	Spacer	1
10	20-146-008	Spring, compression spring	1
11	99-112-006	Pin, clevis	1
12	33008	<sup>3</sup> / <sub>8</sub> in. USS zinc-plated flat washer	10
13	37024	<sup>3</sup> / <sub>8</sub> in. Nylock insert nut	9
14	65076	<sup>1</sup> / <sub>8</sub> in. x 1in. zinc-plated cotter pin	1
15	20-537-018	Brake pad assembly	1
16	11105	<sup>3</sup> / <sub>8</sub> in. – 16 x 1in. HHCS #2 zinc-plated bolt	1
17	33622	<sup>3</sup> / <sub>8</sub> in. zinc-plated lock washer	1
18	65078	<sup>1</sup> / <sub>8</sub> in. x 1 <sup>1</sup> / <sub>2</sub> in. zinc-plated cotter pin	1

## SWA-48-PMO Exploded View and Bill of Materials

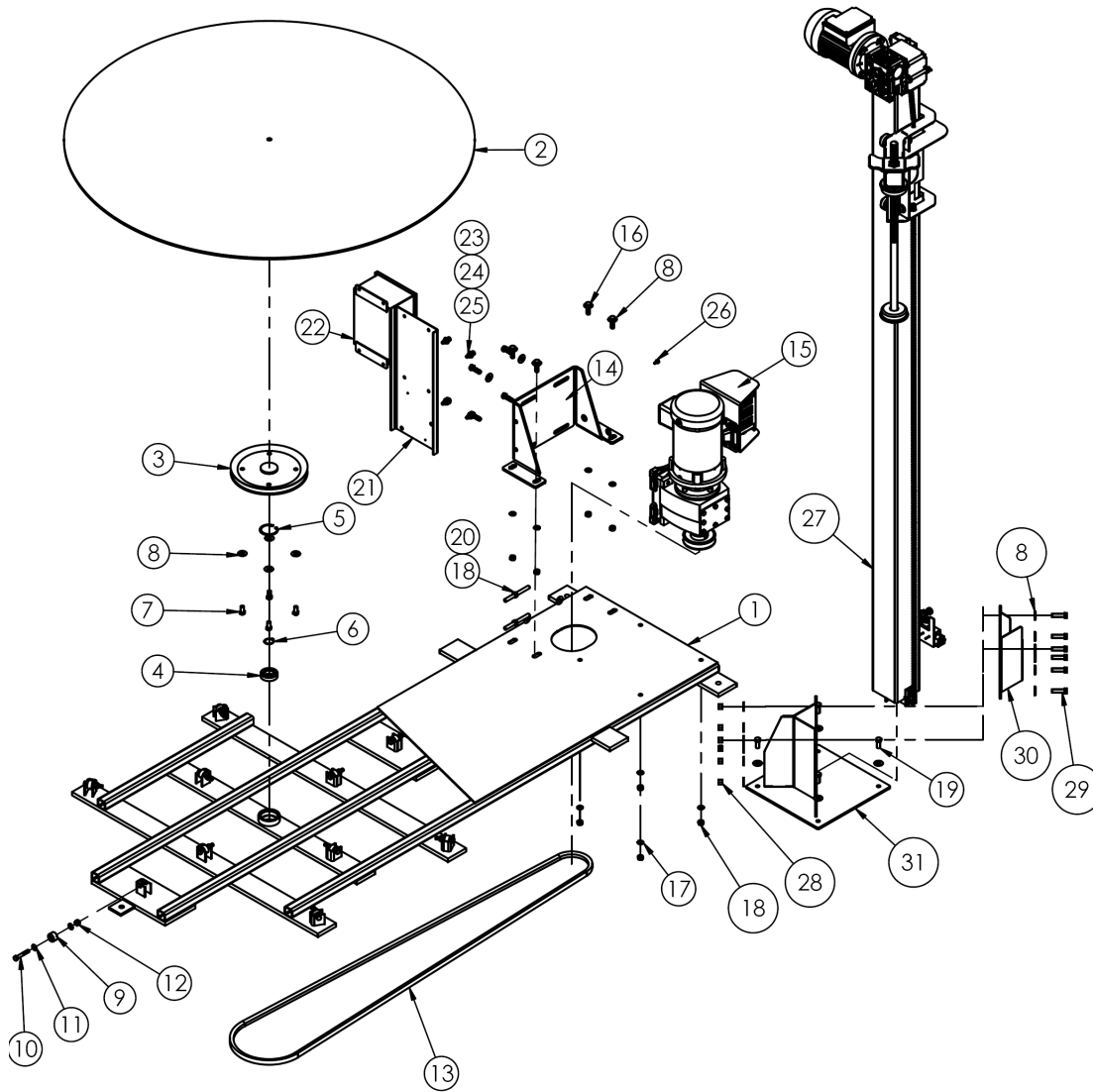

Item	Part no.	Description	Qty.	Item	Part no.	Description	Qty.
1	20-514-006	Weldment, main frame	1	17	33622	Split lock washer, carbon steel, medium z-finish, , 3/8"	12
2	20-513-001	Weldment, turntable/deck	1	18	36106	Hex nut, gr. A, z-plated, , 3/8"-16	10
3	20-542-006	Weldment, pulley/pin	1	19	11105	Hex bolt, gr. A, z-plated, , 3/8"-16 x 1"	4
4	20-110-001	Single row ball bearing, shielded	1	20	25552	Socket set screw, bk oxide, , 3/8"-16 x 4"	2
5	20-117-001	Internal retaining ring, 2"	1	21	20-016-136	Bracket, junction box mount, formed	1
6	20-117-003	External retaining ring, 1" diameter shaft	1	22	01-029-007	Box, 6x8x4 junction box w/ lid, not NEMA 4	1
7	11103	Hex bolt, gr. A, zinc plated, 3/8"-16 x 3/4"	4	23	11005	Bolt, HHCS, #2, z-plated, 1/4"-20UNC x 1"	4
8	33008	Flat washer, low carbon, USS, z-plated, 3/8"	28	24	33618	Medium split lock washer, , 1/4"	4
9	20-110-003	Cam roller with seal	10	25	36102	Hex nut, gr. A, z-plated, , 1/4"-20	4
10	11061	Bolt, HHCS, #2, z-plated, 5/16"-18 x 2"	10	26	31802	Screw, self-tapping	2
11	33004	Flat washer, USS, z-plated, 1/4"	28	27	20-001-115	Subassembly, mast, powered (-PMO)	1
12	37021	Nylon insert lock nut, gr. 2, z-finish, , 5/16"-18	10	28	37024	Nylon insert lock nut, gr. 2, zinc finish, , 3/8"-16	6
13	20-042-020	Belt, B115	1	29	11109	Hex bolt, gr. A, zinc finish, , 3/8"-16 x 1 1/2"	6
14	20-516-020	Weldment, bracket	1	30	20-016-114	Bracket, clamp, formed	1
15	20-641-006	Subassembly, control box/motor, 115VAC	1	31	20-516-014	Weldment, post, bracket	1
16	13107	Bolt, HHCS, #5, z-plated, , 3/8"-16 x 1 1/4"	8				

### Powered Mast Subassembly (20-001-115) Exploded View & Bill of Materials

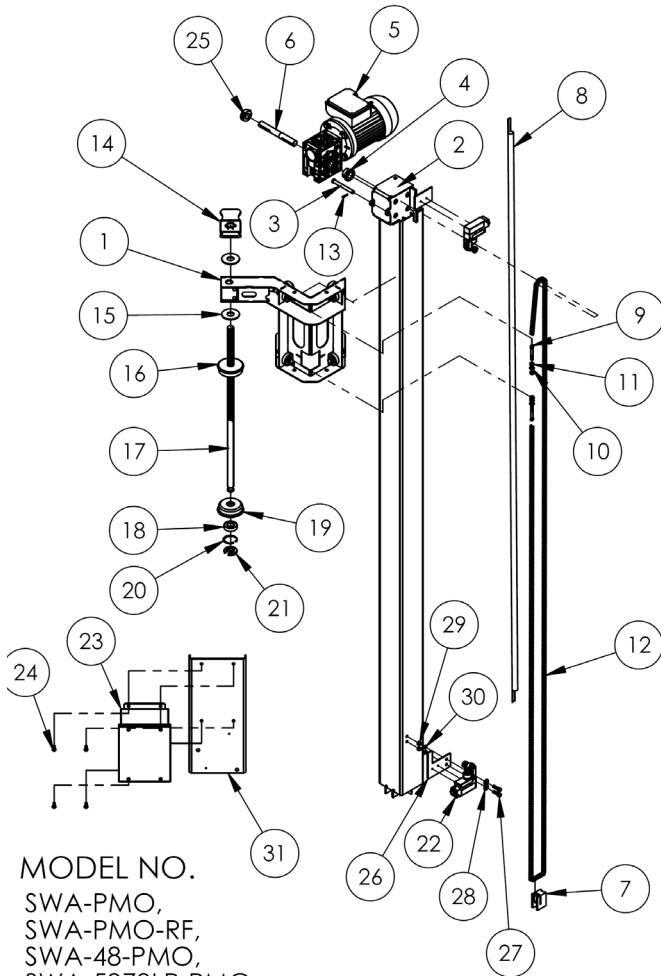

MODEL NO.  
 SWA-PMO,  
 SWA-PMO-RF,  
 SWA-48-PMO,  
 SWA-5070LP-PMO,  
 SWA-5070LP-PMO-RF,  
 SWA-5460-PMO,  
 SWA-5460-PMO-RF,  
 SWA-51-AR5-PMO,  
 SWA-51-AR5-PMO-RF,  
 POW-CAR-PMO,  
 POW-CAR-PMO-RF

Item	Part no.	Description	Qty.
1	20-538-006	Subassembly, carriage without brake	1
2	20-514-083	Subassembly, mast, powered	1
3	20-112-018	Pin, retaining	1
4	20-042-009	Sprocket, drive	1
5	20-141-004	Motor, gearbox	1
6	20-026-007	Sprocket shaft w/ keyways, gearbox	1
7	20-042-022	Chain guide	1
8	20-034-001	Guard, conduit	1
9	21-145-008	Eyebolt	2
10	33076	Flat washer, #12, SAE, z-finish	2
11	36102	Hex nut, gr. A, z-plated, 1/4"-20	4
12	20-042-039	Sprocket, chain	1
13	65074	Cotter pin	1
14	20-620-001	Weldment, rod tension wing nut	1
15	20-113-003	Washer, fiber, 7/8"ID, 2.25"OD	2
16	20-014-005	Tube, retainer	1
17	20-014-116	Frame, rod, wrap retainer	1
18	20-110-002	Bearing, ball	1
19	20-014-006	Tube, retainer	1
20	68061	Internal retaining ring, 1 5/8"	1
21	20-113-022	Spacer, lock	1
22	01-022-001	Limit switch with roller arm	2
23	01-029-007	Junction box w/ lid, 6x8x4, not NEMA 4	1
24	32106	Screw, drill & tap, #12-24 x 7/8"	4
25	34308	Split shaft collar, low carbon steel, black oxide finish, 3/4"	1
26	20-016-140	Bracket, limit switch	1
27	11005	Bolt, HHCS, #2, z-plated, 1/4"-20 x 1"	2
28	33004	Flat washer, USS, z-plated, 1/4"	2
29	37018	Nylon lock nut, gr. 2, z-finish, 1/4"-20	2
30	33618	Medium split lock washer, 1/4"	2
31	20-016-136	Bracket, junction box mount, formed	1

### Stretch wrap carriage subassembly exploded view & bill of materials (20-538-005)

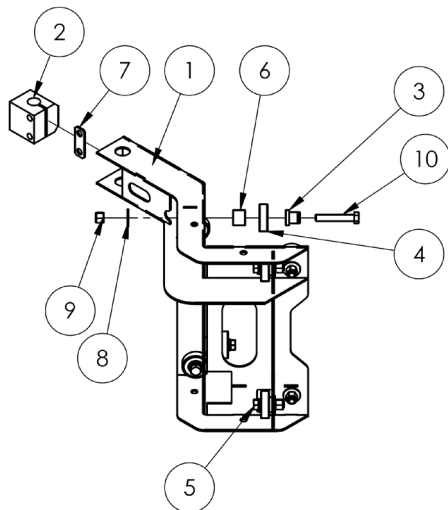

Item	Part no.	Description	Quantity
1	20-514-067	Weldment, carriage frame	1
2	20-145-010	Specialty hardware, clamp, wrap, mounting	1
3	21-113-021	Spacer, bearing shaft	8
4	20-110-006	Roller bearing	8
5	11109	3/8in. - 16 x 1 1/2in. HHCS #2 zinc-plated bolt	4
6	21-113-020	Spacer, bearing	4
7	20-113-023	Spacer	1
8	33008	3/8in. USS zinc-plated flat washer	8
9	37024	3/8in. Nylock insert nut	8
10	11112	3/8in. - 16 x 2 1/4in. HHCS #2 zinc-plated bolt	4

## Operating the Powered Mast

NOTE: Numbers in parentheses ( ) correspond to item numbers in the *Powered Mast Subassembly* bill of materials on p. 11.

Units equipped with the powered mast option (-PMO) use an electric motor and gearbox (5) to raise and lower the stretch wrap carriage. The motor and gearbox interface with a chain-and-sprocket drive system (12 and 4). The chain forms a loop through the mast (2). It attaches to both the top and bottom of the stretch wrap carriage (1). When the sprocket turns clockwise, the chain is pulled up the mast, which causes the carriage to rise. The carriage descends when the sprocket turns counterclockwise. A 2-button, handheld controller allows the operator to select the direction the carriage travels, i.e. UP or DOWN. The carriage only moves while a button is pressed and will maintain position when the button is released. Limit switches (item 22 on p. 11) at the top and bottom of the mast prevent the carriage from being raised, or lowered, too far.

Use the handheld controller to change position of the stretch wrap as necessary while wrapping an item.

### HANDHELD CONTROLLER

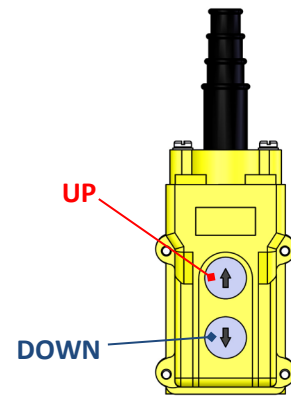

## Labeling Diagrams

Each unit should be labeled as shown in the diagram. However, label content and location are subject to change so your product might not be labeled exactly as shown. Compare this diagram to your *Record of Satisfactory Condition*. If there are differences between actual labeling and this diagram, adapt the diagram to reflect actual labeling. Replace all labels that are damaged, missing, or not easily readable (e.g. faded). To order replacement labels or to inquire whether your unit is properly labeled, contact the technical service and parts department online at [http://www.vestilmfg.com/parts\\_info.htm](http://www.vestilmfg.com/parts_info.htm) or by calling (260) 665-7586 and asking for the Parts Department.

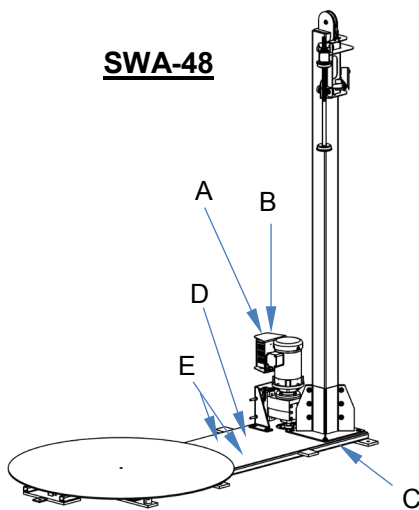

**SWA-48**

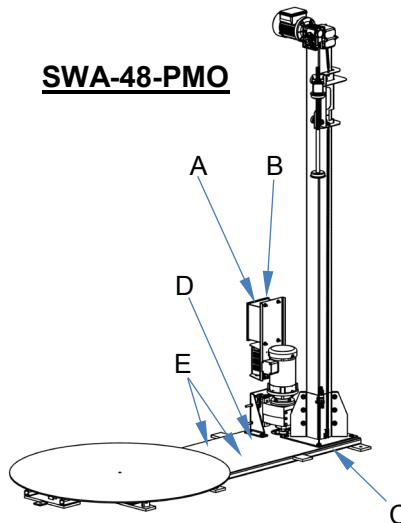

**SWA-48-PMO**

A: Label 248

NOTICE	NOTA	AVIS
POWER SUPPLY: 115 V/1 Phase/60 HZ		
CONTROL VOLTAGE: 24 V AC		
CORRIENTE: 115 Volt/1 Fase/60 HZ		
VOLTAJE DE CONTROL: 24V CA		
ALIMENTATION ÉLECTRIQUE: 115 V/1 Monophasé/ 60 HZ		
VOLTAGE DE CONTRÔLE: 24V AC		

B: Label 221

<b>⚠ DANGER</b>	<b>ELECTRICAL SHOCK</b> Shut power off and consult owners manual before working on this equipment.	221 Rev 0111
<b>⚠ PELIGRO</b>	<b>EI GOLPE ELECTRICO</b> Corte la corriente consulte el manual de propietario antes de trabajar en este equipo.	
<b>⚠ DANGER</b>	<b>CHOC ELECTRIQUE</b> Couper le courant et consulter le manuel d'utilisation avant de travailler sur cet équipement	

C: Label 204

<b>⚠ WARNING</b>	<b>⚠ ADVERTENCIA</b>	<b>⚠ AVERTISSEMENT</b>
SECURE FRAME TO FLOOR	ASEGURE EL BASTIDOR AL PISO	FIXER SOLIDEMENT LE CADRE AU PLANCHER

D: Label 287

MODEL/MODÉLO/MODÈLE _____	
STATIC CAPACITY (evenly distributed) _____	lbs.
LA CAPACIDAD CONSTANTE (distribuida uniformemente) _____	kgs.
CAPACITÉ STATIQUE (distribuée régulièrement) _____	kgs.
SERIAL/SERIE/SÉRIE _____	

287 REV 0812

E: Label 220

<b>⚠ WARNING</b>	<b>⚠ ADVERTENCIA</b>	<b>⚠ AVERTISSEMENT</b>
KEEP CLEAR WHEN IN USE	MANTENGASE ALEJADO CUANDO SE ESTA OPERANDO	SE TENIR À DISTANCE LORS DU FONCTIONNEMENT

220 REV 0111

## Record of Satisfactory Condition

Before using the machine for the first time, record its appearance and operation. Photograph the unit from multiple angles. Take close range photographs of the anchor points, carriage, labels, motor(s), motor speed controller, the foot pedal, and junction box and handheld controller (-PMO equipped units only). Include written observations about each part. Raise and lower the shrink wrap carriage. Include notes about how rapidly the carriage moves up and down the mast as well as how it sounds during operation. Activate the turntable. Record your observations as well as sounds heard during operation. Record the maximum turntable rotation speed to provide a reference for evaluating drive belt slippage during future maintenance checks.

This record establishes satisfactory condition. Compare the results of every inspection to the record to determine if the unit is in satisfactory condition. DO NOT use the machine unless it is in satisfactory condition. If repairs are necessary, only install manufacturer-approved replacement parts.

## Inspections & Maintenance

Before inspecting the machine, disconnect it from the electrical power supply. Tag the unit "Out of Service". Inspect the unit to determine if it is in *satisfactory condition*. Repair or replace all items that are not in satisfactory condition before returning the unit to service.

### **Before each use, including first use, examine the unit for:**

1. Frayed or damaged wires.
2. Damage or structural deformation to the stretch-wrap mast, the machine's frame, or the turntable.
3. Damage to any of the machine's control or power transmission components, particularly to the foot switch, its guard, or its cord.
4. Unusual noise or binding, or evidence thereof.
5. Smooth and proper movement of the stretch-wrap mast carriage.

### **Monthly Inspections:** Examine the machine for any of the following conditions at least once per month.

1. Worn or damaged electrical wires.
2. Damage to the motor speed control. If the speed control's enclosure has been broken, the drive should be replaced.
3. Looseness of the drive belt. Slipping of the drive belt will cause it to wear out rapidly. The turntable will rotate more slowly than it should or not at all. The belt tension is adjusted by the socket-head screws on the side of the gear reducer mounting bracket. See [Adjusting Belt Tension](#) on page 5.
4. Wear or impact damage to the edge of the turntable plate.



Sharp edges or burrs can develop at the edge of the turntable plate when forks scrape the top of the plate or a fork impacts the edge of the plate during loading/unloading. To prevent potential injury to personnel, these must be filed, sanded or ground smooth.

5. Damaged or worn load bearings. This is indicated by a scraping sound from the turntable during operation and by grooves developing on the bottom side of the turntable.
6. Wear of the turntable's main bearing. Check that the turntable is parallel with the top of the machine's frame and that there is no wobble when the edge of the turntable is shaken.
7. Excessive wear to the mast carriage slides, or to the fiber washer under the stretch-wrap material.
8. The integrity of the frame anchors and for cracks in the concrete around them.
9. Unusual noises or movement during operation.
10. All the information, safety, and warning labels being in place and in good condition.
11. Clean off dirt and debris, particularly built up underneath the turntable. In the event of a sudden and severe shock load to the turntable's drive system; such as when the spinning load is instantly stopped due to a fork truck backing into the load, damage may occur to the drive system components (belt, pulleys, torque limiter, gear reducer, motor). Such damage is not covered under warranty. The gear reducer uses. Disassembly of the gear reducer will void the warranty, and at the manufacturer's discretion may void all warranty of the stretch-wrap machine.

## Troubleshooting

Problem	Cause	Action
<ul style="list-style-type: none"> <li>• The turntable does not rotate.</li> </ul> <p style="text-align: center;">Or</p> <ul style="list-style-type: none"> <li>• The turntable will not rotate without assistance, rotates slower when loaded, or will not achieve maximum speed.</li> </ul>	<ul style="list-style-type: none"> <li>No power supply voltage.</li> <li>• Speed control at its slowest setting</li> <li>• No control signal from the foot switch.</li> <li>• Motor controller fault, or defective motor controller.</li> <li>• Broken or slipping belt.</li> </ul>	<p>Check for 120V at the outlet into which the machine is connected. Find cause of power supply loss before resupplying power.</p> <p>If the turntable cord is plugged into the pigtail at the powered mast's enclosure, verify that the powered mast cord is plugged into an outlet.</p> <ul style="list-style-type: none"> <li>• Increase the turntable speed at the knob on the front of the motor controller.</li> <li>• Check the foot switch and its cable for continuity.</li> <li>• Check the display on the controller for a fault code. Contact the factory.</li> <li>• If the fan on the drive motor is spinning, lift the mast end of the machine to inspect the belt.</li> </ul>
<p>The powered mast motor or control enclosure hums, chatters, or buzzes, and the film carriage does not move, or it moves only slowly.</p>	<ul style="list-style-type: none"> <li>• Excess voltage drop to the motor due to: power wire size too small, wire run too long, or incoming voltage too low.</li> <li>• Damage to the mast or carriage.</li> <li>• Low control voltage or bad connection in control circuit.</li> </ul>	<ul style="list-style-type: none"> <li>• Check power supply for adequacy.</li> <li>• Check incoming voltage while the motor is running. Correct by installing a circuit with larger wire, eliminating extension cords, or installing a buck/boost transformer.</li> <li>• Visually inspect the carriage and mast for signs of damage or excessive wear.</li> <li>• Verify 24 VAC at transformer secondary. Inspect all wires and connections in the mast control enclosure for looseness, etc.</li> </ul>
<p>Powered mast must carriage will raise but it will not lower.</p>	<ul style="list-style-type: none"> <li>• See as last item above.</li> <li>• Transformer fuse is blown.</li> <li>• No power supply voltage.</li> <li>• Mast limit switch is engaged or bad.</li> <li>• Control relay 1 CR, left side in the enclosure, contact is burnt.</li> <li>• Control relay 1 CR has become loose.</li> <li>• Control relay 2 CR has become loose.</li> <li>• Control relay 2 CR is defective.</li> <li>• Bad connection in control circuit.</li> <li>• Physical blockage of the structure.</li> </ul>	<ul style="list-style-type: none"> <li>• See paragraph above.</li> <li>• Test with meter; replace if bad. Replace with the same fuse type and ampere value.</li> <li>• See first item at the top of the page.</li> <li>• Inspect and test switch. Replace if bad.</li> <li>• Inspect contact. Clean contact or replace relay if burnt. Check for 120V at the motor relay.</li> <li>• Verify that the relay is firmly in place.</li> <li>• See last paragraph above.</li> <li>• Inspect and test control relay 2 CR. Replace if bad.</li> <li>• Test all parts of circuit with meter.</li> <li>• Inspect for foreign material or objects that might block the carriage path.</li> </ul>

## SWA-48 Electrical Circuit Diagrams (20-124-012 Rev. G)



Disconnect the unit from electrical power before beginning work on the electrical system. Only qualified, trained individuals should attempt troubleshooting and repair of this equipment.

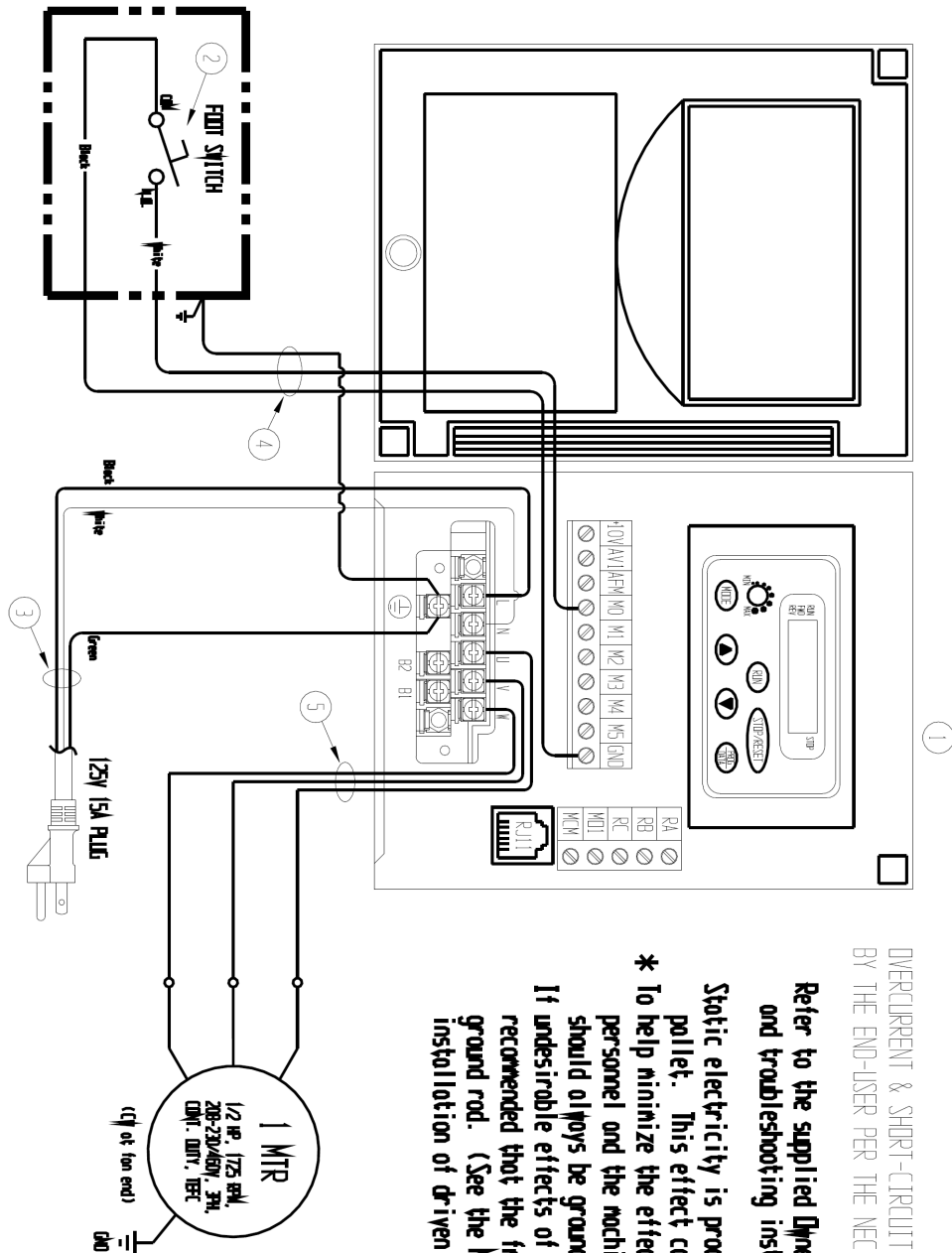

OVERCURRENT & SHORT-CIRCUIT PROTECTION ARE TO BE PROVIDED BY THE END-USER PER THE NEC (NFPA 70) AND LOCAL CODES.  
 Refer to the supplied **Owner's Manual** for adjustment and troubleshooting instructions.

Static electricity is produced while stretch-topping a pallet. This effect can intensify in dry air conditions. \* To help minimize the effects of generated static on personnel and the machine's control, the control should always be grounded to the machine frame. If undesirable effects of static are experienced, it is recommended that the frame be bonded to a driven ground rod. (See the NEC for details regarding installation of driven grounding electrodes.)

**BE SURE ALL POWER IS OFF BEFORE ATTEMPTING TO WORK ON THIS EQUIPMENT!**  
**CAUTION: SERVICE WORK SHOULD BE PERFORMED ONLY BY TRAINED & QUALIFIED PERSONNEL.**

# SWA-48-PMO Electrical Circuit Diagrams (20-124-015 Rev. J)



Disconnect the unit from electrical power before beginning work on the electrical system. Only qualified, trained individuals should attempt troubleshooting and repair of this equipment.

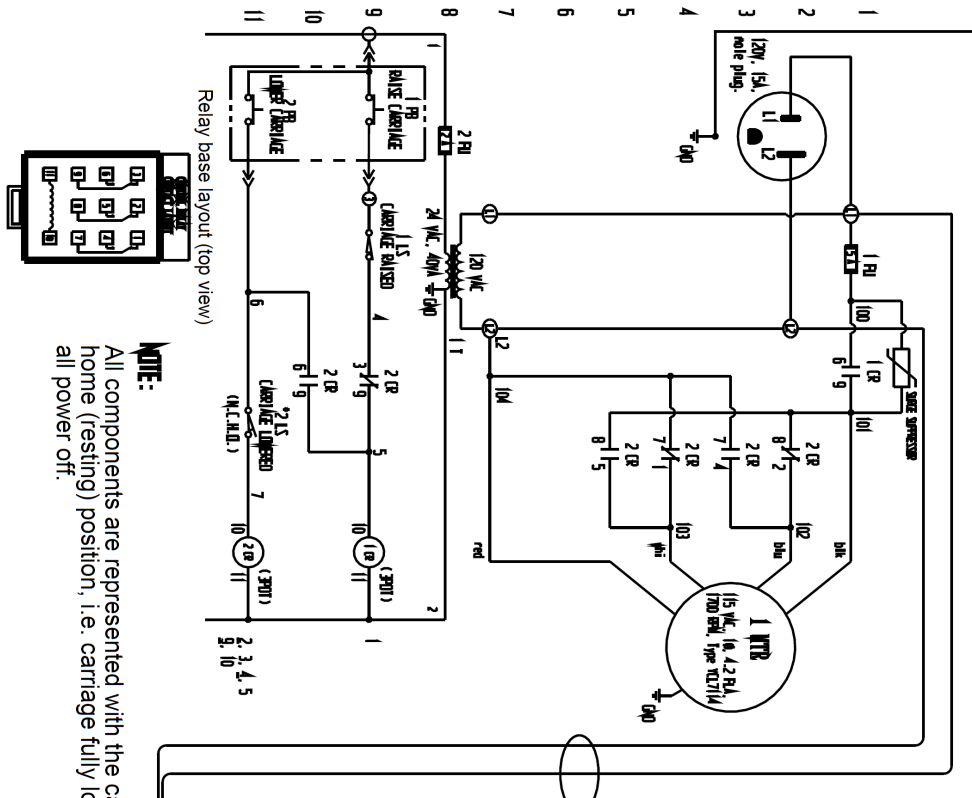

Static electricity is normally generated during shrink-wrapping operations, and is more intense in dry air. The machine control must always be grounded to the frame, to minimize the effects of static on people and electronics.

Bond the frame to a driven grounding rod, if static effects are too intense. Refer to the NEC for proper driven rod installation procedures. This drawing depicts typical potentiometer settings for various control parameters. Refer to controller manual for maintenance, adjustment, and troubleshooting procedures.

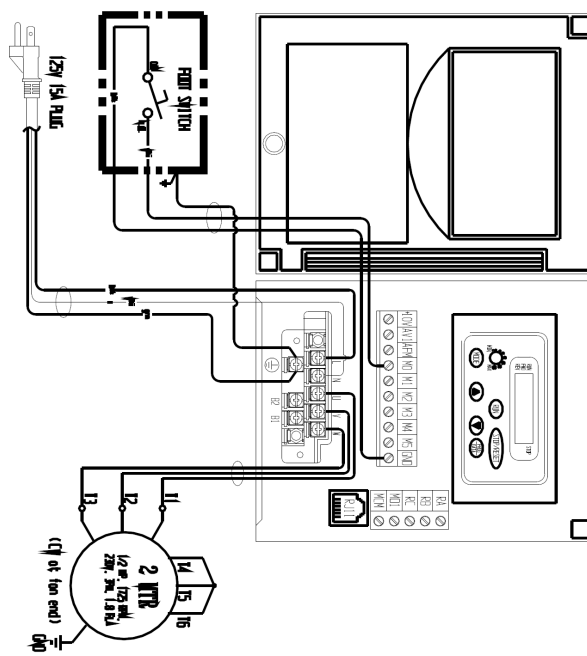

**NOTE:**  
All components are represented with the carriage in its home (resting) position, i.e. carriage fully lowered and all power off.



## LIMITED WARRANTY

Vestil Manufacturing Corporation (“Vestil”) warrants this product to be free of defects in material and workmanship during the warranty period. Our warranty obligation is to provide a replacement for a defective, original part covered by the warranty after we receive a proper request from the Warrantee (you) for warranty service.

### Who may request service?

Only a warrantee may request service. You are a warrantee if you purchased the product from Vestil or from an authorized distributor AND Vestil has been fully paid.

### Definition of “original part”?

An original part is a part used to make the product as shipped to the Warrantee.

### What is a “proper request”?

A request for warranty service is proper if Vestil receives: 1) a photocopy of the Customer Invoice that displays the shipping date; AND 2) a written request for warranty service including your name and phone number. Send requests by one of the following methods:

<u>US Mail</u>	<u>Fax</u>	<u>Email</u>
Vestil Manufacturing Corporation 2999 North Wayne Street, PO Box 507 Angola, IN 46703	(260) 665-1339 <u>Phone</u> (260) 665-7586	<a href="mailto:info@vestil.com">info@vestil.com</a> Enter “Warranty service request” in the subject field.

In the written request, list the parts believed to be defective and include the address where replacements should be delivered. After Vestil receives your request for warranty service, an authorized representative will contact you to determine whether your claim is covered by the warranty. Before providing warranty service, Vestil will require you to send the entire product, or just the defective part (or parts), to its facility in Angola, IN.

### What is covered under the warranty?

The warranty covers defects in the following original, dynamic parts: motors, hydraulic pumps, motor controllers, and cylinders. It also covers defects in original parts that wear under normal usage conditions (“wearing parts”), such as bearings, hoses, wheels, seals, brushes, and batteries.

### How long is the warranty period?

The warranty period for original dynamic components is 1 year. For wearing parts, the warranty period is 90 days. Both warranty periods begin on the date Vestil ships the product to the Warrantee. If the product was purchased from an authorized distributor, the periods begin when the distributor ships the product. Vestil may, at its sole discretion, extend a warranty period for products shipped from authorized distributors by up to 30 days to account for shipping time.

### If a defective part is covered by the warranty, what will Vestil do to correct the problem?

Vestil will provide an appropriate replacement for any *covered* part. An authorized representative of Vestil will contact you to discuss your claim.

### What is not covered by the warranty?

The Warrantee (you) is responsible for paying labor costs and freight costs to return the product to Vestil for warranty service.

### Events that automatically void this Limited Warranty.

- Misuse;
- Negligent assembly, installation, operation or repair;
- Installation/use in corrosive environments;
- Inadequate or improper maintenance;
- Damage sustained during shipping;
- Collisions or other accidents that damage the product;
- Unauthorized modifications: Do not modify the product IN ANY WAY without first receiving written authorization from Vestil.

### Do any other warranties apply to the product?

Vestil Manufacturing Corp. makes no other express warranties. All implied warranties are disclaimed to the extent allowed by law. Any implied warranty not disclaimed is limited in scope to the terms of this Limited Warranty. Vestil makes no warranty or representation that this product complies with any state or local design, performance, or safety code or standard. Noncompliance with any such code or standard is not a defect in material or workmanship.

